



## Capacitance Level Switch



[www.fine-tek.com](http://www.fine-tek.com)



# PRODUCT INTRODUCTION

## ■ OPERATING PRINCIPLE

The Fine-tek Capacitance Switch for liquids and solids can be used in mediums such as liquids, pastes, syrups, powders, granules, flakes and chips. It's broad application and rugged build makes it a highly versatile across all industries.

Capacitance switches rely on electrical capacitance theory (the ability of a medium to store electrical energy). When an electrical circuit has two separated conductive plates, the space between the plates acts as a capacitor and stores the electrical energy. Mediums have differing conductivity and dielectric constants which affects their energy storage capability. When the switch comes into contact with the medium, it can detect a change in the surroundings and this actuates the switch accordingly.

Materials with high conductivity or high dielectric constants such as water tend to have high capacitance. The opposite applies for low conductive substances such as popcorn, wax or air. Thus the switch works well in mediums with reasonably high dielectric constants or conductive solutions.

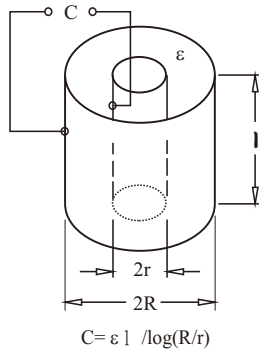

## ■ CONSTRUCTION

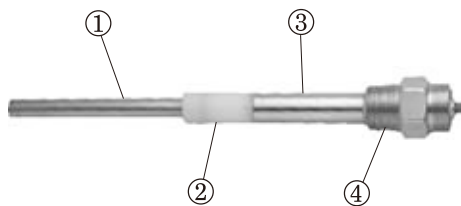

- 1. Probe : SUS304 or SUS316
- 2. Insulation : UPE or PTFE
- 3. Grounding Sleeve : SUS304 or SUS316
- 4. Connection : SUS304 or SUS316  
1"PT (default) or 3/4"PT(option)

## ■ FEATURES AND APPLICATIONS

As Capacitance Level Switch has no moving parts inside the device, it will not be affected by friction. It is suitable for powder or liquid application easy to install. The customer can choose the types for his requirements.

1. **Standard Type (SA110 & SA111 A/B/C)**  
Suitable for general use.
2. **Hi-Temp Type (SA120 & SA128 A/B/C)**  
Suitable for high temperature environment.
3. **Anti-Corrosion Type (SA130 & SA132 A/B/C)**  
Suitable for corrosive environment.
4. **Remote Probe Type (SA140 A/B/C)**  
For use with vibrator equipped with tank.
5. **Wire-Probe Type (SA150 A/B/C)**  
Suitable for silo or large-size tank.
6. **Plate-Probe Type (SA160 A/B/C)**  
Suitable for granules and at lower position of tank side.
7. **Explosion-Proof Type (SA270 ~ SA279)**  
Ex dia II C T4~T6, DIP A21 T<sub>A</sub>, T3~T6
8. **Explosion-Proof Type (SA370 ~ SA378)**  
Ex ia IIC T3~T6  
Equipped with SA-75U signal conditioner can be used in hazardous areas.
9. **Anti-Static Type (SA180 & SA181 A/B/C)**  
Suitable for electrostatic environment  
(It won't be damaged by the electrostatic discharge)

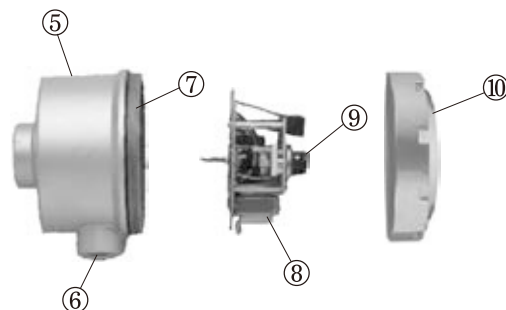

- 5. Housing : ADC-12 Aluminum IP65
- 6. Conduit opening : 1/2"PF or 3/4"PF
- 7. O-RING : NBR
- 8. PC board : A, B, C, D Type
- 9. Sensitivity adjustment : 10pf (std.), 20pf, 40pf
- 10. Cover : ADC-12 Aluminum

# STANDARD MODEL

<b>Dimensions</b>			
<b>Order No.</b>	<b>[STANDARD MODEL] SA110 A/B/C</b>	<b>[STANDARD MODEL] SA111 A/B/C</b>	<b>[HI-TEMP. MODEL] SA120 A/B/C</b>
<b>Ambient temp.</b>	-20°C~60°C	-20°C~60°C	-20°C~60°C
<b>Operating temp.</b>	-20°C~80°C	-20°C~80°C	-20°C~200°C
<b>Operation pressure</b>	20kg/cm <sup>2</sup>	20kg/cm <sup>2</sup>	20kg/cm <sup>2</sup>
<b>Probe material</b>	SUS 304/316	SUS 304/316	SUS 304/316
<b>Insulated material</b>	UPE	UPE	PEEK
<b>Connection</b>	1"PT Screw (SUS)	1"PT Screw (SUS)	1"PT Screw (SUS)
<b>Sensitivity range</b>	10pF (std.)	10pF (std.)	10pF (std.)
<b>Weight</b>	Approx. 1.9kg	Approx. 1.9kg	Approx. 2.4kg
<b>Housing spec.</b>	Aluminum IP65		
<b>Supply voltage</b>	110/220Vac ± 10% or 19~24Vdc		
<b>Delay time</b>	0~6 sec		
<b>Power consumption</b>	2W		
<b>Output rating</b>	Relay: 5A/250Vac/30Vdc, NPN 100mA		

# STANDARD TYPE

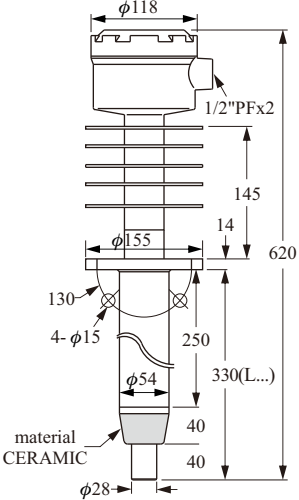
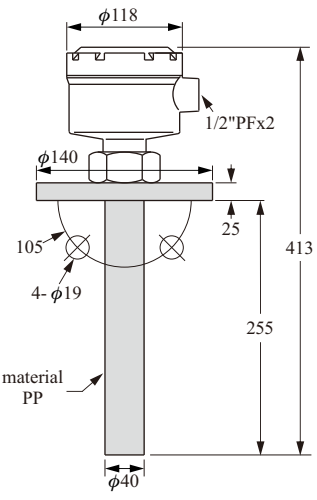
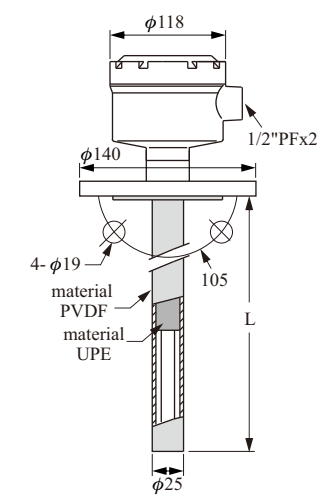
Dimensions			
Order No.	[SUPER HI-TEMP. MODEL] SA128 A/B/C	[CORROSION-PROOF MODEL] SA130 A/B/C	[CORROSION-PROOF MODEL] SA132 A/B/C
Ambient temp.	-20°C~60°C	-20°C~60°C	-20°C~60°C
Operating temp.	-20°C~800°C	-20°C~80°C	-20°C~120°C
Operation pressure	ATM	20kg/cm <sup>2</sup>	20kg/cm <sup>2</sup>
Probe material	SUS 304/316	SUS 304 Coating PP	SUS304 Coating PVDF
Insulated material	CERAMIC	UPE	UPE
Connection	2-1/2"x5kg/cm <sup>2</sup> Flange(SUS)	1-1/2"x10kg/cm <sup>2</sup> Flange(PP)	1-1/2"x10kg/cm <sup>2</sup> Flange(SUS) (5mm PVDF)
Sensitivity range	10pF (std.)	10pF (std.)	10pF (std.)
Weight	Approx. 6.5kg	Approx. 2kg	—————
Housing spec.	Aluminum IP65		
Supply voltage	110/220Vac±10% or 19~24Vdc		
Delay time	0~6 sec		
Power consumption	2W		
Output rating	Relay: 5A/250Vac/30Vdc,NPN 100mA		

# STANDARD TYPE

Dimensions			
Order No.	[REMOTE PROBE MODEL] SA140 A/B/C	[WIRE-PROBE MODEL] SA150 A/B/C	[PLATE MODEL] SA160 A/B/C
Ambient temp.	-20°C~60°C		
Operating temp.	-20°C~80°C		
Operation pressure	20kg/cm <sup>2</sup>		
Probe material	SUS 304/316		
Insulated material	UPE		
Connection	1"PT Screw (SUS)	1"PT Screw (SUS)	2-1/2"x 5kg/cm <sup>2</sup> Flange (SUS)
Sensitivity range	30pF (std.)	10pF (std.)	10pF (std.)
Weight	Approx. 3kg	Approx. 4.1kg	Approx. 3.2kg
Housing spec.	Aluminum IP65		
Supply voltage	110/220Vac ± 10% or 24Vdc ± 20%	110/220Vac ± 10% or 19~24Vdc	
Delay time	0~8 sec	0~6 sec	
Power consumption	2W		
Output rating	Relay: 5A/250Vac/30Vdc, NPN 100mA		

# STANDARD MODEL

<b>Dimensions</b>		
<b>Order No.</b>	<b>[ANTI-STATIC MODEL] SA180 A/B/C</b>	<b>[HI-TEMP. ANTI-STATIC MODEL] SA181 A/B/C</b>
<b>Ambient temp.</b>	-20°C~60°C	-20°C~60°C
<b>Operating temp.</b>	-20°C~80°C	-20°C~200°C
<b>Operation pressure</b>	20kg/cm <sup>2</sup>	20kg/cm <sup>2</sup>
<b>Probe material</b>	UPE Coating	PTFE Coating
<b>Insulated material</b>	UPE	PTFE
<b>Connection</b>	1"PT Screw (SUS)	1"PT Screw (SUS)
<b>Sensitivity range</b>	10pF (std.)	10pF (std.)
<b>Weight</b>	Approx. 2kg	Approx. 2.5kg
<b>Housing spec.</b>	Aluminum IP65	
<b>Supply voltage</b>	110/220Vac ± 10% or 19~24Vdc	
<b>Delay time</b>	0~6 sec	
<b>Power consumption</b>	2W	
<b>Output rating</b>	Relay: 5A/250Vac/30Vdc, NPN 100mA	

# EXPLOSION PROOF MODEL

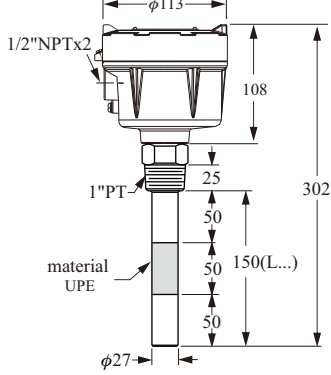
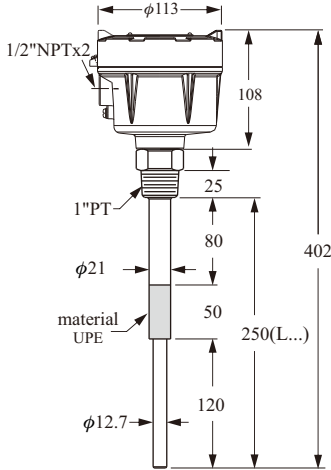
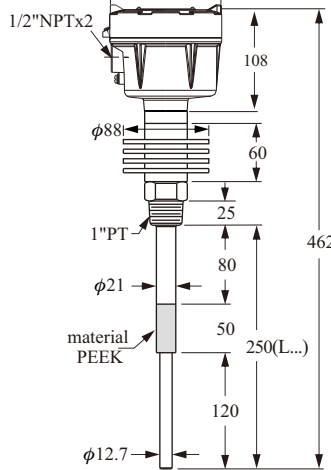
Dimensions			
Order No.	[STANDARD MODEL] SA270	[STANDARD MODEL] SA271	[STANDARD MODEL] SA272
Ambient temp.	-20°C~60°C	-20°C~60°C	-20°C~60°C
Operating temp.	-20°C~80°C	-20°C~80°C	-20°C~200°C
Operating pressure	20kg/cm <sup>2</sup>	20kg/cm <sup>2</sup>	20kg/cm <sup>2</sup>
Probe material	SUS 304/316	SUS 304/316	SUS 304/316
Insulated material	UPE	UPE	PEEK
Connection	1"PT Screw (SUS)	1"PT Screw (SUS)	1"PT Screw (SUS)
Sensitivity range	10pF (std.)	10pF (std.)	10pF (std.)
Weight	Approx. 1.9kg	Approx. 2.4kg	Approx. 4.1kg
Housing spec.	Aluminum IP65		
Supply voltage	110/220Vac±10% or 24Vdc±20%		
Enclosure protection	Ex d/ia IIC T3~T6 Gb/Ga, DIP A20/A21 T <sub>A</sub> , T3~T6		
Power consumption	2W		
Output contact rating	Relay: 5A/250Vac/28Vdc		
	3 wire NPN output, max. load current 400mA		
	3 wire PNP output, max. load current 400mA		
	4 wire NPN/PNP output, max. 400mA/60Vdc		

# EXPLOSION PROOF MODEL

<b>Dimensions</b>			
<b>Order No.</b>	<b>[CORROSION-PROOF MODEL] SA273</b>	<b>[CORROSION-PROOF MODEL] SA274</b>	<b>[WIRE-PROBE MODEL] SA275</b>
<b>Ambient temp.</b>	-20°C~60°C	-20°C~60°C	-20°C~60°C
<b>Operating temp.</b>	-20°C~80°C	-20°C~120°C	-20°C~80°C
<b>Operating pressure</b>	ATM	20kg/cm <sup>2</sup>	20kg/cm <sup>2</sup>
<b>Probe material</b>	SUS 304/316(PP Coating)	SUS 304/316	SUS 304/316 Cable
<b>Insulated material</b>	UPE	UPE	UPE
<b>Connection</b>	1-1/2"x10kg/cm <sup>2</sup> (PP)	1-1/2"x10kg/cm <sup>2</sup> (SUS) W / 5mm PVDF Cushion	1"PT Screw (SUS)
<b>Sensitivity range</b>	10pF (std.)	10pF (std.)	10pF (std.)
<b>Weight</b>	Approx. 1.9kg	—————	Approx. 4.1kg
<b>Housing spec.</b>	Aluminum IP65		
<b>Supply voltage</b>	110/220Vac± 10% or 24Vdc± 20%		
<b>Enclosure protection</b>	Ex d/ia IIC T3~T6 Gb/Ga, DIP A20/A21 T <sub>A</sub> , T3~T6		
<b>Power consumption</b>	2W		
<b>Output contact rating</b>	Relay: 5A/250Vac/28Vdc		
	3 wire NPN output, max. load current 400mA		
	3 wire PNP output, max. load current 400mA		
	4 wire NPN/PNP output, max. 400mA/60Vdc		

# EXPLOSION PROOF MODEL

Dimensions			
Order No.	<b>[PLATE MODEL] SA276</b>	<b>[HI-TEMP ANTI-STATIC MODEL] SA277</b>	<b>[ANTI-STATIC MODEL] SA278</b>
Ambient temp.	-20°C~60°C	-20°C~60°C	-20°C~60°C
Operating temp.	-20°C~80°C	-20°C~200°C	-20°C~80°C
Operating pressure	20kg/cm <sup>2</sup>	20kg/cm <sup>2</sup>	20kg/cm <sup>2</sup>
Probe material	SUS 304/316	PTFE Coating	UPE Coating
Insulated material	UPE	PTFE	UPE
Connection	2-1/2"x 5kg/cm <sup>2</sup> Flange (SUS)	1"PT Screw (SUS)	1"PT Screw (SUS)
Sensitivity range	10pF (std.)	10pF (std.)	10pF (std.)
Weight	Approx. 3.2kg	Approx. 3.1kg	Approx. 2kg
Housing spec.	Aluminum IP65		
Supply voltage	110/220Vac± 10% or 24Vdc± 20%		
Enclosure protection	Ex d/ia IIC T3~T6 Gb/Ga, DIP A20/A21 T <sub>A</sub> , T3~T6		
Power consumption	2W		
Output contact rating	Relay: 5A/250Vac/28Vdc		
	3 wire NPN output, max. load current 400mA		
	3 wire PNP output, max. load current 400mA		
	4 wire NPN/PNP output, max. 400mA/60Vdc		

# INTRINSICALLY SAFE MODEL

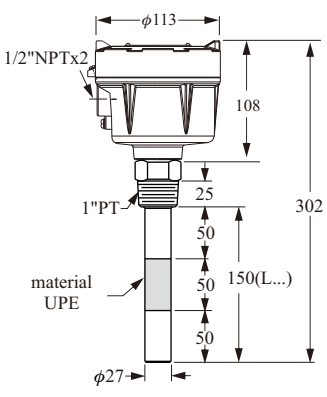
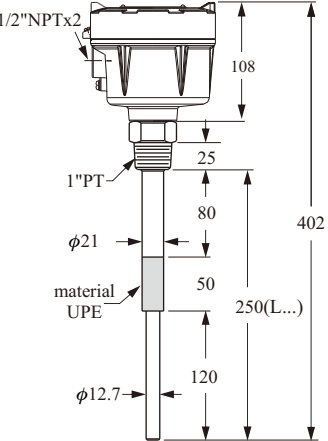
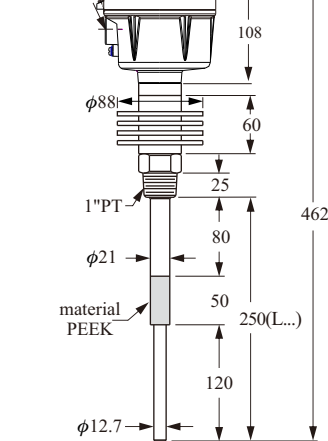
Dimensions			
Order No.	SA370(WITH SA-75U)	SA371(WITH SA-75U)	SA372(WITH SA-75U)
Ambient temp.	-20°C~60°C	-20°C~60°C	-20°C~60°C
Operating temp.	-20°C~80°C	-20°C~80°C	-20°C~200°C
Operation pressure	20kg/cm <sup>2</sup>	20kg/cm <sup>2</sup>	20kg/cm <sup>2</sup>
Probe material	SUS 304/316	SUS 304/316	SUS 304/316
Insulated material	UPE	UPE	PEEK
Connection	1"PT Screw (SUS)	1"PT Screw (SUS)	1"PT Screw (SUS)
Sensitivity range	10pF (std.)	10pF (std.)	10pF (std.)
Weight	Approx. 1.9kg	Approx. 2.4kg	Approx. 2.4kg
Housing spec.	Aluminum IP65		
Supply voltage	16~24Vdc		
Enclosure protection	Ex ia IIC T3~T6		
Power consumption	2W		
Output rating	NPN 100mA		

# INTRINSICALLY SAFE MODEL

Dimensions			
Order No.	[CORROSION-PROOF MODEL] SA373(WITH SA-75U)	[CORROSION-PROOF MODEL] SA374(WITH SA-75U)	[WIRE-PROBE MODEL] SA375(WITH SA-75U)
Ambient temp.	-20°C~60°C	-20°C~60°C	-20°C~60°C
Operating temp.	-20°C~80°C	-20°C~120°C	-20°C~80°C
Operation pressure	20kg/cm <sup>2</sup>	20kg/cm <sup>2</sup>	20kg/cm <sup>2</sup>
Probe material	SUS 304/316(PP Coating)	SUS 304/316	SUS 304/316 Cable
Insulated material	PTFE or UPE	UPE	UPE
Connection	1-1/2"x10kg/cm <sup>2</sup> (PP)	1-1/2"x10kg/cm <sup>2</sup> (SUS) W / 5 mm PVDF Cushion	1"PT Screw (SUS)
Sensitivity range	10pF (std.)	10pF (std.)	10pF (std.)
Weight	Approx. 1.9kg	—	Approx. 4.1kg
Housing spec.	Aluminum IP65		
Supply voltage	16~24Vdc		
Enclosure protection	Ex ia IIC T3~T6		
Power consumption	2W		
Output rating	NPN 100mA		

# INTRINSICALLY SAFE MODEL

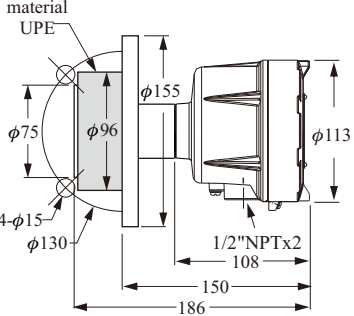
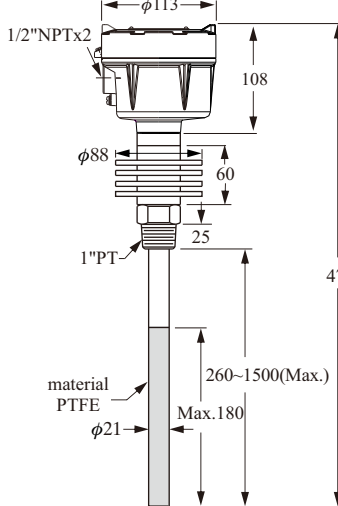
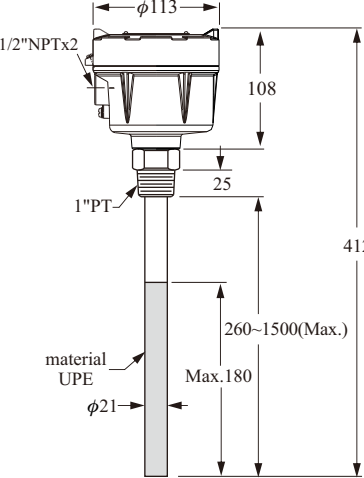
Dimensions			
<b>Order No.</b>	<b>[PLATE MODEL] SA376(WITH SA-75U)</b>	<b>[HI-TEMP. ANSI-STATIC MODEL] SA377(WITH SA-75U)</b>	<b>[ANTI-STATIC MODEL] SA378(WITH SA-75U)</b>
<b>Ambient temp.</b>	-20°C~60°C	-20°C~60°C	-20°C~60°C
<b>Operating temp.</b>	-20°C~80°C	-20°C~200°C	-20°C~80°C
<b>Operation pressure</b>	20kg/cm <sup>2</sup>	20kg/cm <sup>2</sup>	20kg/cm <sup>2</sup>
<b>material</b>	SUS 304/316	PTFE	UPE Coating
<b>Insulated material</b>	UPE	PTFE	UPE
<b>Connection</b>	2-1/2"x 5kg/cm <sup>2</sup> Flange (SUS)	1"PT Screw (SUS)	1"PT Screw (SUS)
<b>Sensitivity range</b>	10pF (std.)	10pF (std.)	10pF (std.)
<b>Weight</b>	Approx. 3.2kg	Approx. 3.1kg	Approx. 2kg
<b>Housing spec.</b>	Aluminum IP65		
<b>Supply voltage</b>	16~24Vdc		
<b>Enclosure protection</b>	Ex ia IIC T3~T6		
<b>Power consumption</b>	2W		
<b>Output rating</b>	NPN 100mA		

# SA-75U INTRINSIC SAFE SIGNAL CONDITIONER

NEPSI PROOF NO. GYB111594

SA-75U Zener barriers inside provide intrinsic safety to SA37□ molex level switch. The unit works uses a current-limiting feature protecting the device from power surges, sparks and other electrical damage.

1. Supply voltage : 110 / 220Vac ± 3%
2. Power consumption : 2W
3. Input signal : NPN transistor  
resistance Ri= 500Ω
4. Output voltage : 16 Vdc
5. Short circuit current : 25mA max.
6. Relay output : SPDT  
10A /30Vdc  
10A /220Vac
7. Operating temp. : -20°C ~ 60°C
8. Weight : 0.3 kg
9. Enclosure rating : Ex (ia) IIC T6

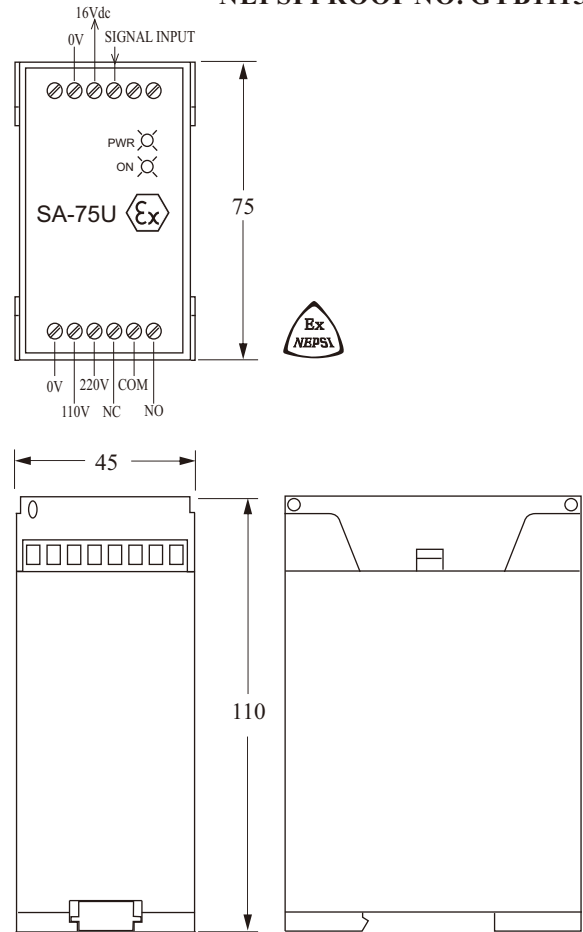

## ■ WIRING CONFIGURATION

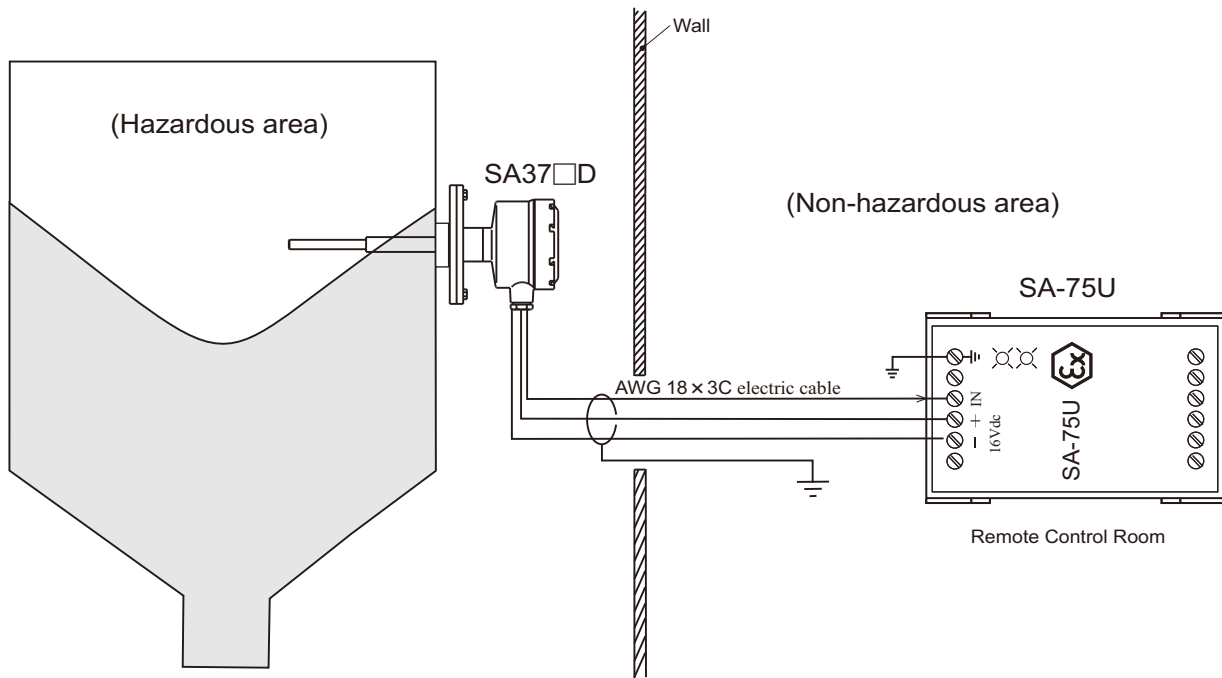

# CALIBRATION

## QUICK CALIBRATION

1. Turn the "SENSITIVITY" to the "H" position.
2. Place a flat screw driver in the "Coarse" coarse hole, turn clockwise until INDICATOR turns on. Check whether "Indicator" light is on or not by turning the "Sensitivity Adj" knob again.
3. If not, repeat procedure.

## SENSITIVITY ADJUSTMENT

1. Initially, the "Indicator" LED will turn off when the tank's material doesn't contact the probe.
2. When making contact with the probe, it will turn on. As soon as LED turns on, adjust the " SENSITIVITY " until the light turns off. Turn the knob " SENSITIVITY " to the middle position between where it turned off and "H"

## PANEL DESCRIPTION

SA110,120,130,150,160,180

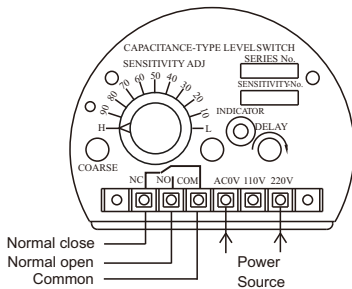

SA 370 D

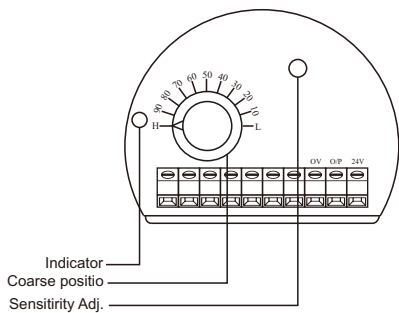

Remote probe model  
SA140 A/B/C

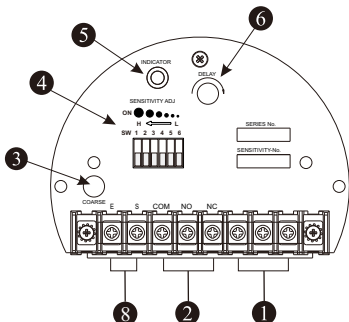

## DELAY FUNCTION CALIBRATION

The default setting is 0 second when material comes into contact with the probe (Indicator ON)

For setting the delay function, turn the screw clockwise. The further clockwise, the longer the delay. The delay function is suitable for mediums with agitators, splashing or level turbulence in the tank.

Explosion proof model  
SA27

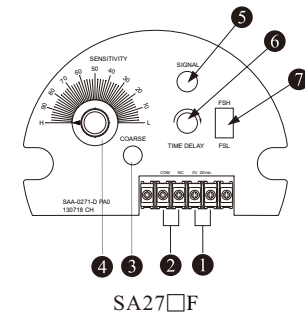
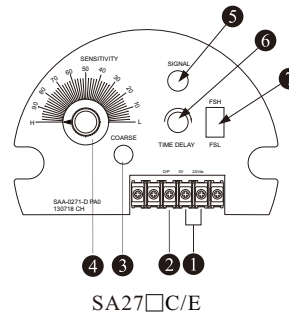
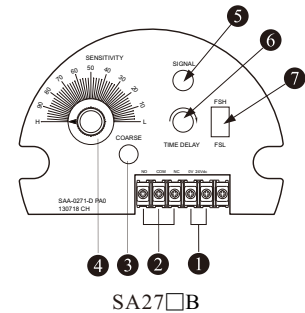
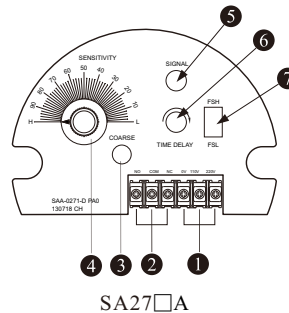

- ① : Power
- ② : Output
- ③ : Coarse position
- ④ : Sensitivity

- ⑤ : Level indicator
- ⑥ : Time delay setting
- ⑦ : Fail-safe switch
- ⑧ : Connect with probe connection

# INSTALLATION NOTICE

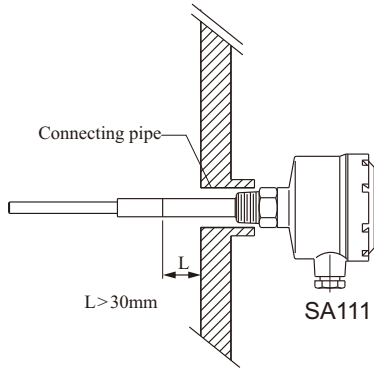

The insulation part should be mounted to protrude 30mm from the vessel wall.

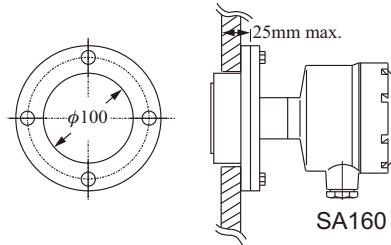

SA160 should be mounted as above.

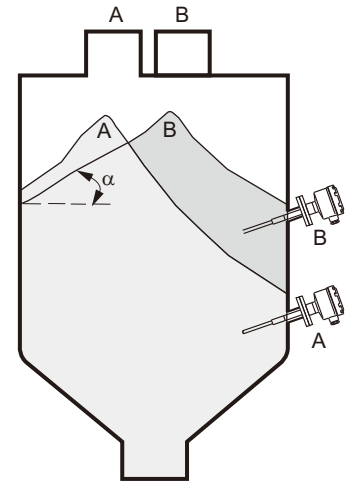

To prevent false readings, check the flow pattern ( angle  $\alpha$  ) of the material and place the probe in the appropriate location.

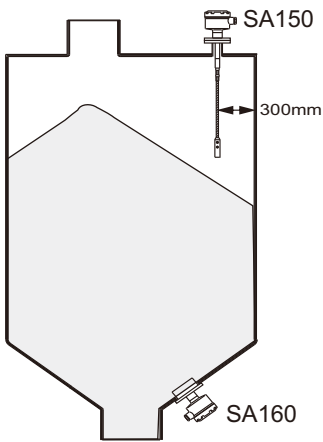

If the probe is mounted on the top, make sure the length of probe long enough to touch the highest level of medium.  
The SA160 MODEL is usually installed at the lower wall of the tank.

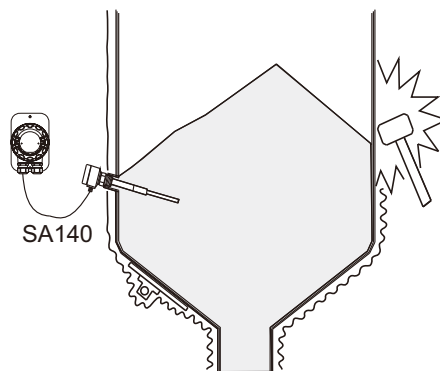

For Non-Stationary or vibrating environment, a separate control unit such as the SA140 is suggested.

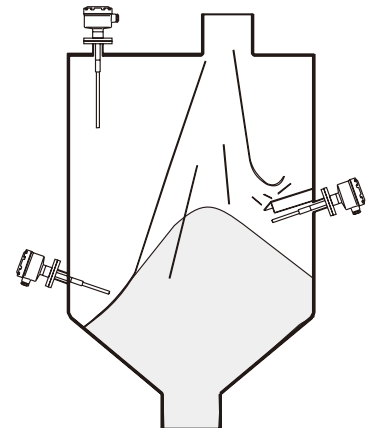

It is suggested to install the probe away from the inlet to reduce the risk of inflowing material damaging the probe. If the probe is near an inlet, it is recommended to place a protective cover 200mm above the probe. The cover should be parallel to the probe and the same length.

# INSTALLATION NOTICE

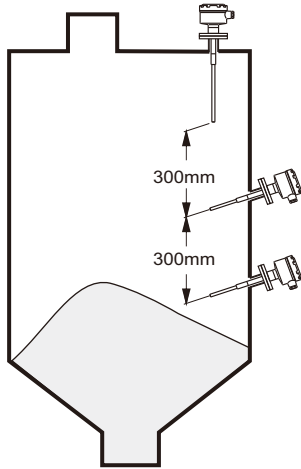

If two parallel probes are mounted, they must be installed separately at least 300 mm to minimize interference .

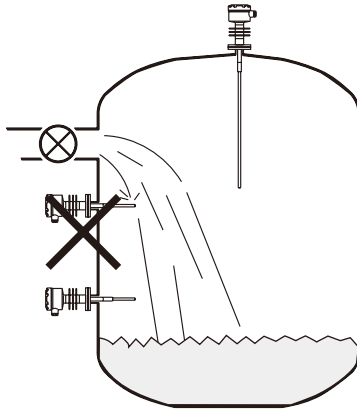

The probe should not be mounted underneath a liquid inlet, otherwise it will switch on erroneously.

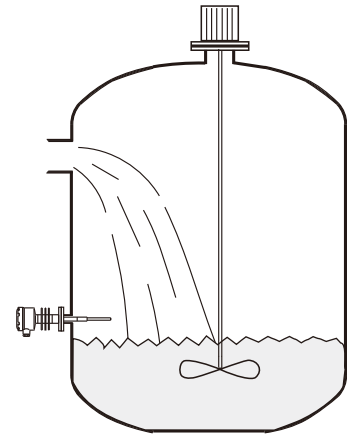

If the tank equips with agitator, please use the time-delay type to prevent fault level detection.

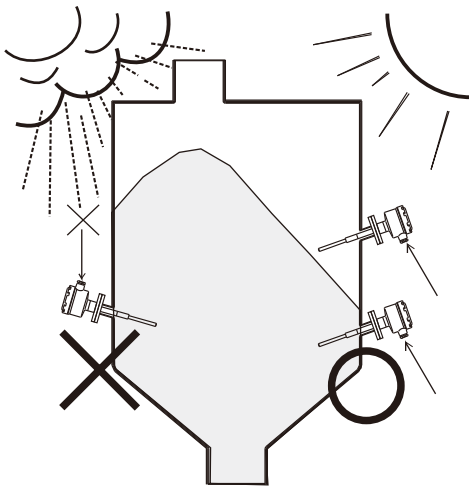

The cable inlet should face downward to avoid rain damage. Tighten the cable with the connecting part.

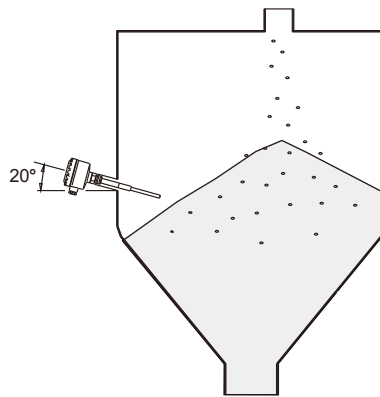

Mounting the probe at a 20° incline will optimize the results and increase sensitivity. It also won't be damaged by the inflowing material.

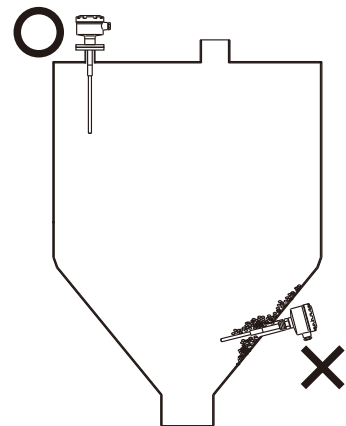

Mounting the probe at top of tank can avoid material bridges from forming. It's helpful to record accurate measurements.

